



PV Manufacturing Lines Planning and Optimisation with InFrame Synapse Simulation Library and AnyLogic

Laurentiu Maniu, acp-IT AG

Simulation Services

Simulation based planning of manufacturing lines

- resource capacity planning
- material flow analysis & layout planning
- planning of storage and transportation processes
- emulation of lines for the testing of factory control software
- ramp-up simulation
- development of modular components for equipment & material handling
- inbound and outbound logistics with infrastructure, warehouse (raw material, finished goods, handling of glass etc.)

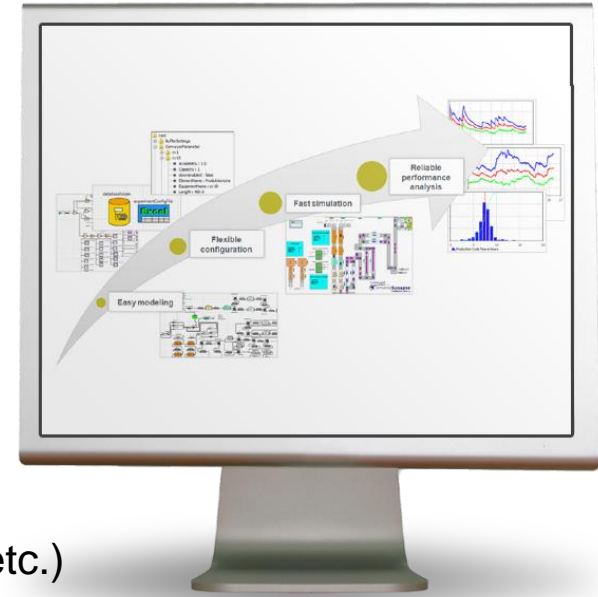

Simulation based optimization of existing manufacturing lines

- performance evaluation based on log data
- development and continuous measurement of key performance indicators such as overall equipment efficiency (OEE)
- bottleneck detection
- optimization of material flow policies

Potential Benefits of Manufacturing Simulation

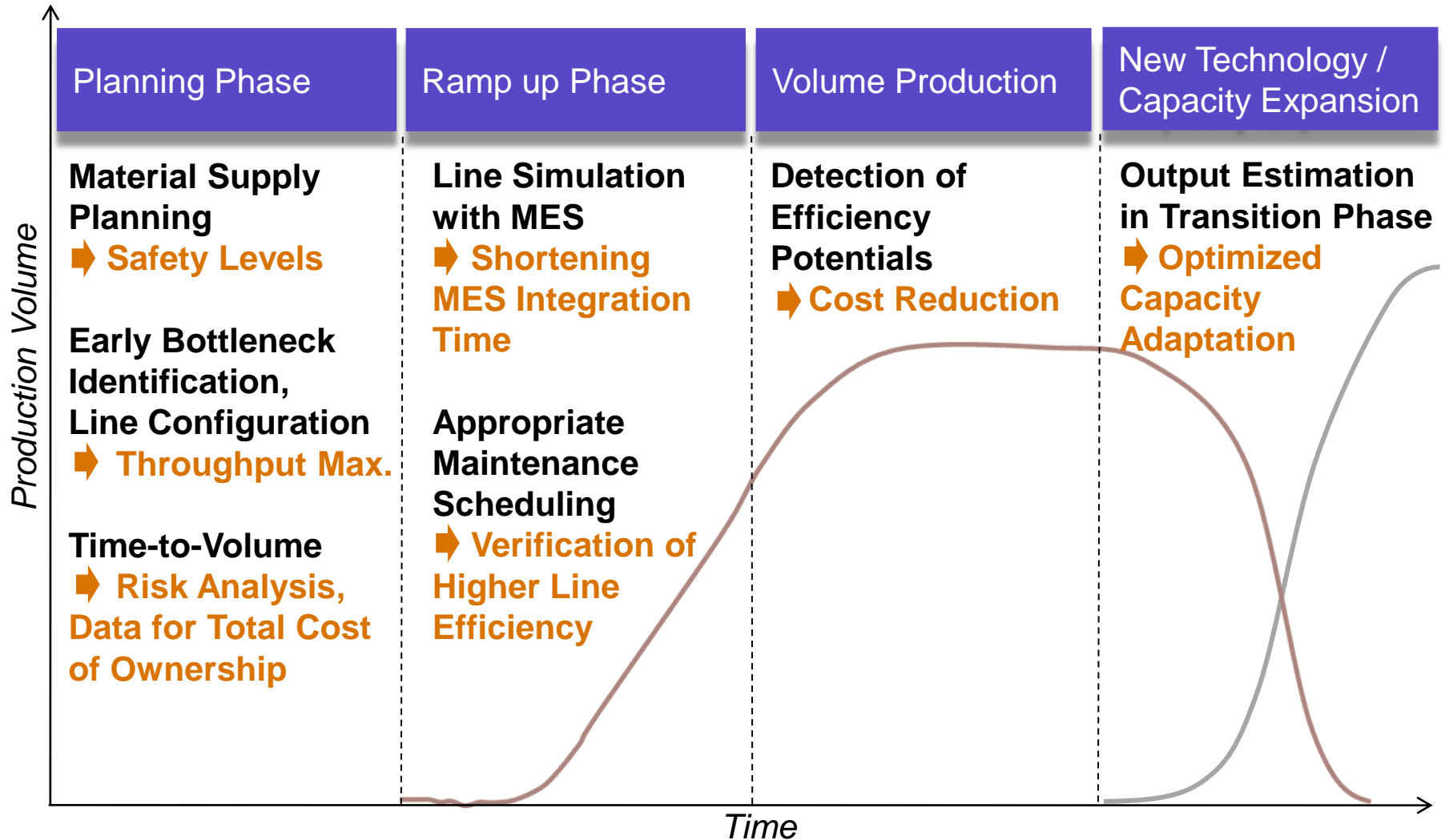

Application of the InFrame Synapse Simulation Library based on AnyLogic Ver. 6

acp-IT has built a powerful Fab simulation suite, oriented on easy modeling, flexible experiment configuration, fast simulation and reliable performance analysis

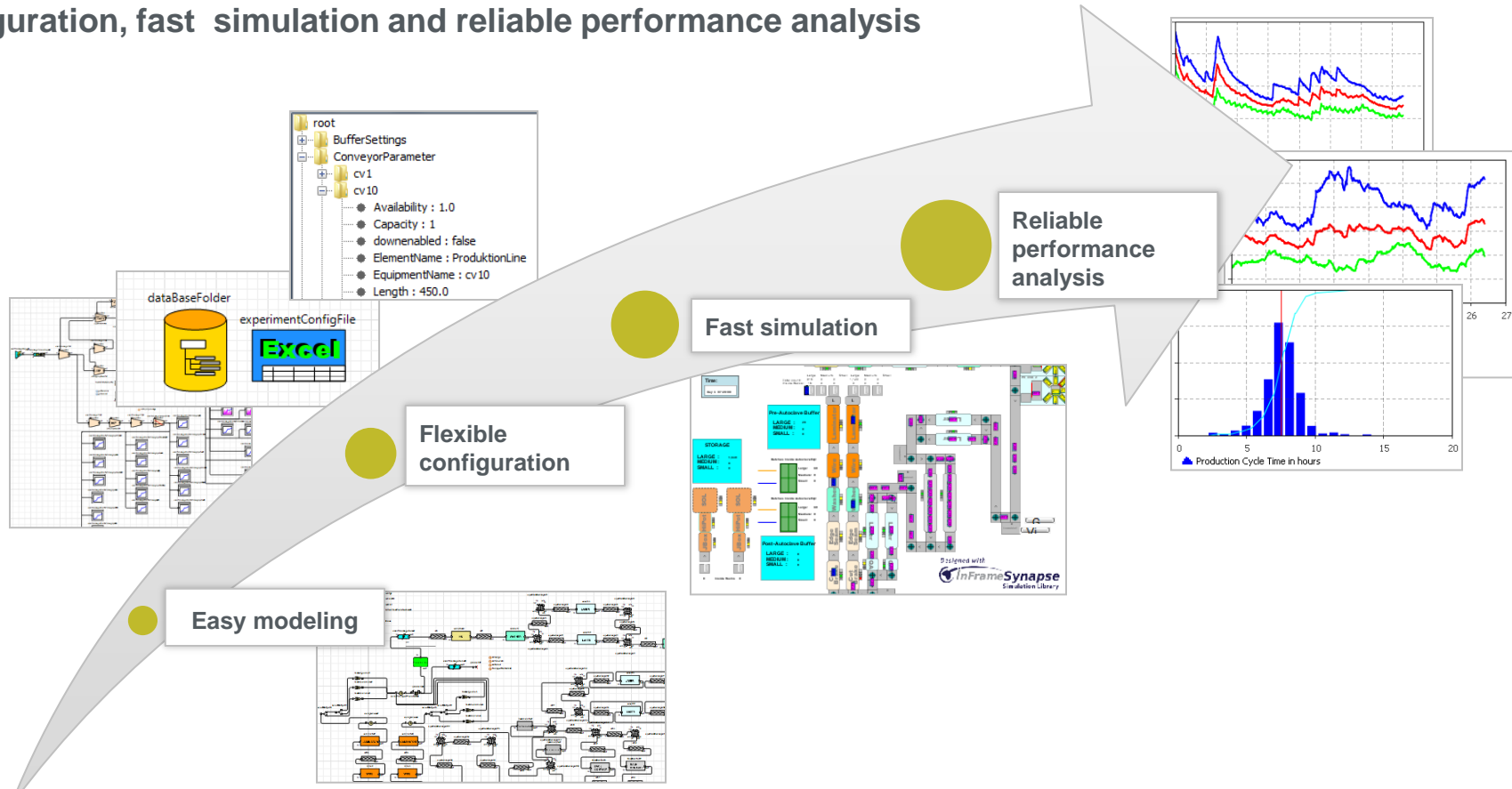

Layout Planning for Thin Film Manufacturing Lines

Flow line with conveyor transport

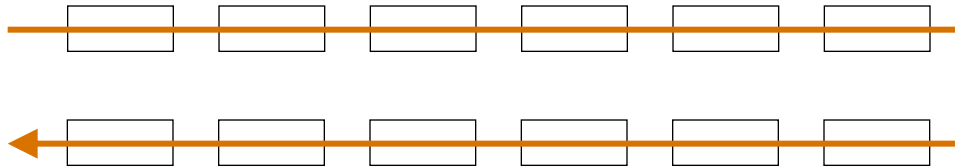

- Substrate queuing in front of critical process steps
 (→ need for several buffering elements)
- + high transport throughput possible

Job shop layout with central transport (handling unit)

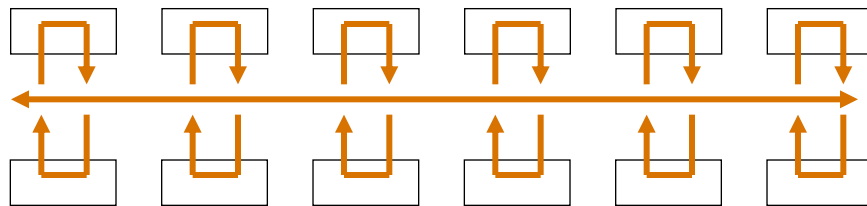

- Central transportation can become the bottleneck
- + More process flexibility & process capacity extension easier

Example layouts from equip. suppliers

Sunfab
 (Applied Materials)

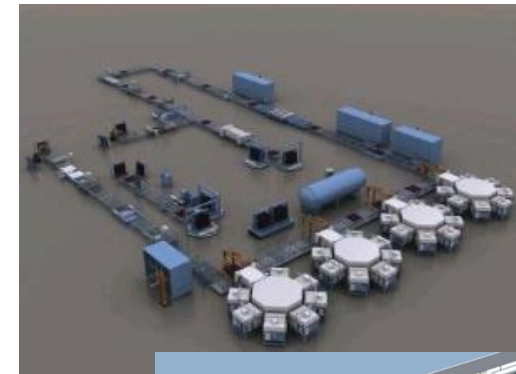

Turnkey solar factory
 (Centrotherm)

➔ Analysis of flow dynamics requires simulation!

The Way to the Base Model ...

for a Thin Film Mfg. Model

1 Process Step Modeling

- Model all process steps & times for each product.
- Capture all throughput dynamics from the equip.

2 Capacity Check

Simulate with factory load (substrate start rate)

- Enough equipment capacity?
- Number of equip. for each equip.-group

3 Mat. Handling Modeling

Model material flow between process steps

- Equip. for execution of transport & mat.handling steps
- Buffering elements
- Configuration of complex material flow policies

4 Throughput Check

- Verify overall throughput
- process & transport & material handling

Seam, wash, laser scribe, PECVD,
Laser scribe, PVD, ...

- Seam → 1 Equip.
- Wash → 1 Equip.
- Laser Scribe → 3 Equip.
- PECVD → 2 Equip. (7 chambers)

...

Conveyor and robots, transport speeds,
spacing, transport capacity, location of
buffers, substrate routing policies
(look ahead), queuing behavior ...

gridlock free substrate routing

cycle time, throughput,
equipment utilization,
max. buffer WIP, ...

Modelling of Thin-Film Manufacturing Line based on InFrame Synapse Simulation Library and AnyLogic

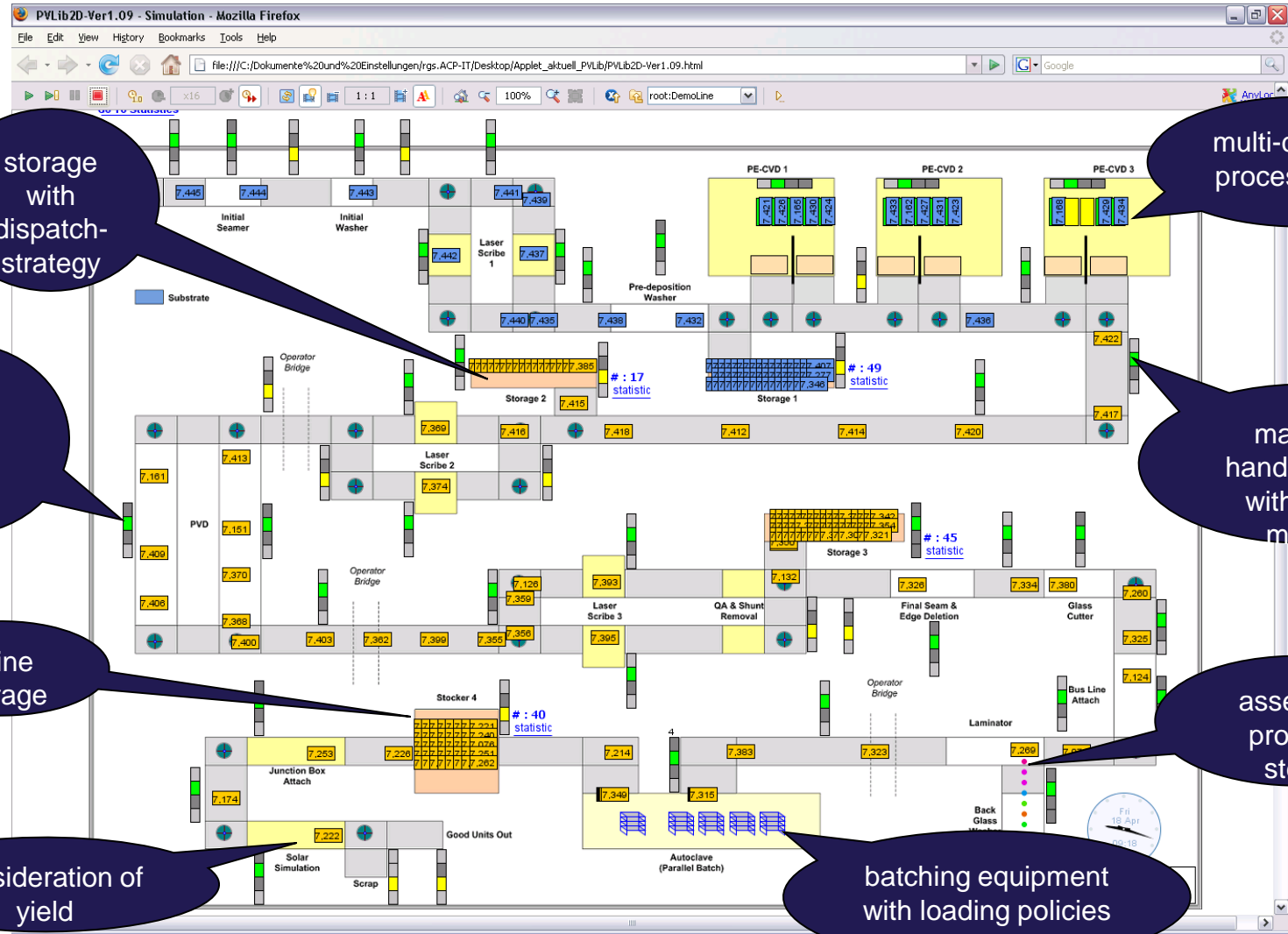

storage with dispatch-strategy

state-model and light tower

inline storage

consideration of yield

multi-chamber process steps

material handling unit with state model

assembly process steps

batching equipment with loading policies

Drag & Drop Modelling and Easy Linking of Library Objects

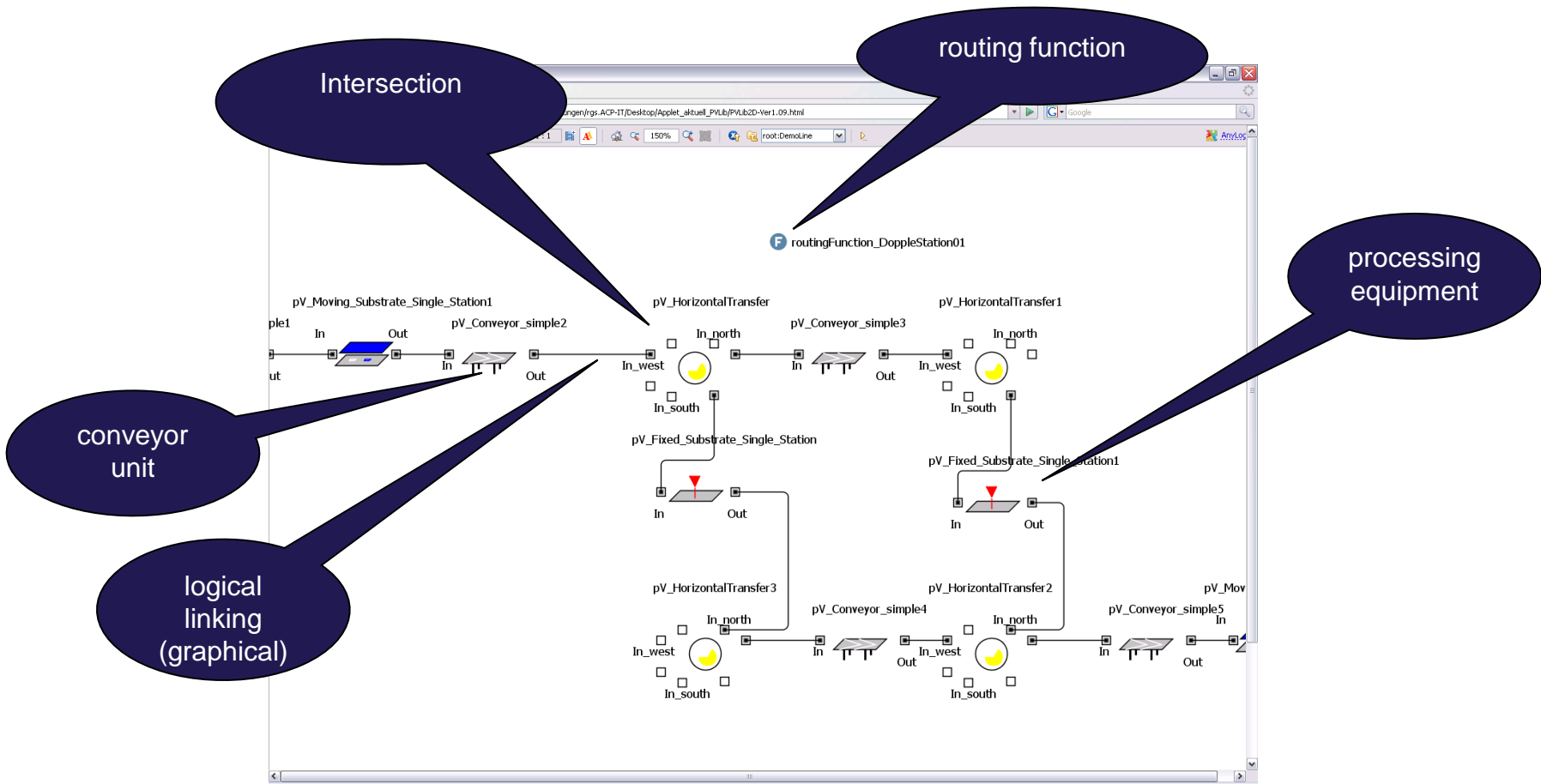

Drag & Drop Modelling of Logical Library Objects and Drag & Drop Positioning in Factory Layout

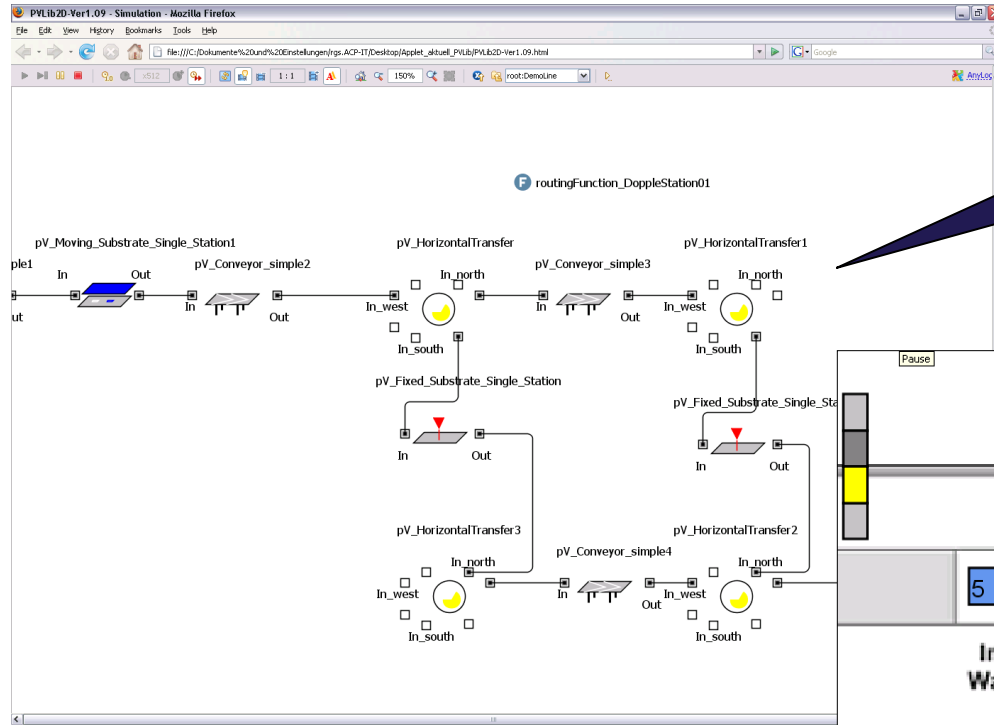

logical modelling in block diagram

animation of material flow and relocation in layout independently of the flow logic – adaptable built-in-animation for the library objects

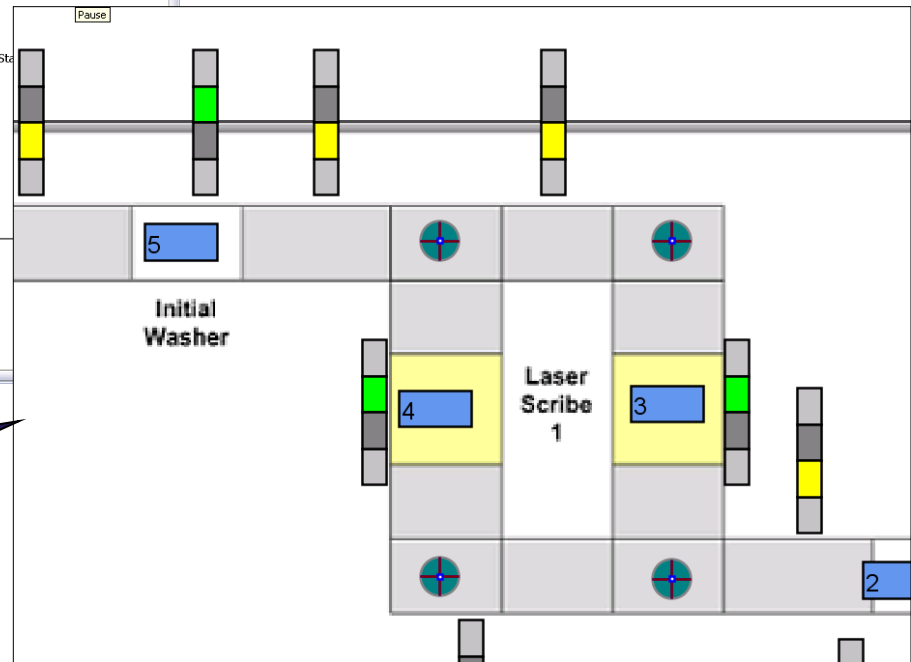

Drag & Drop Modelling of Complex Process Flows

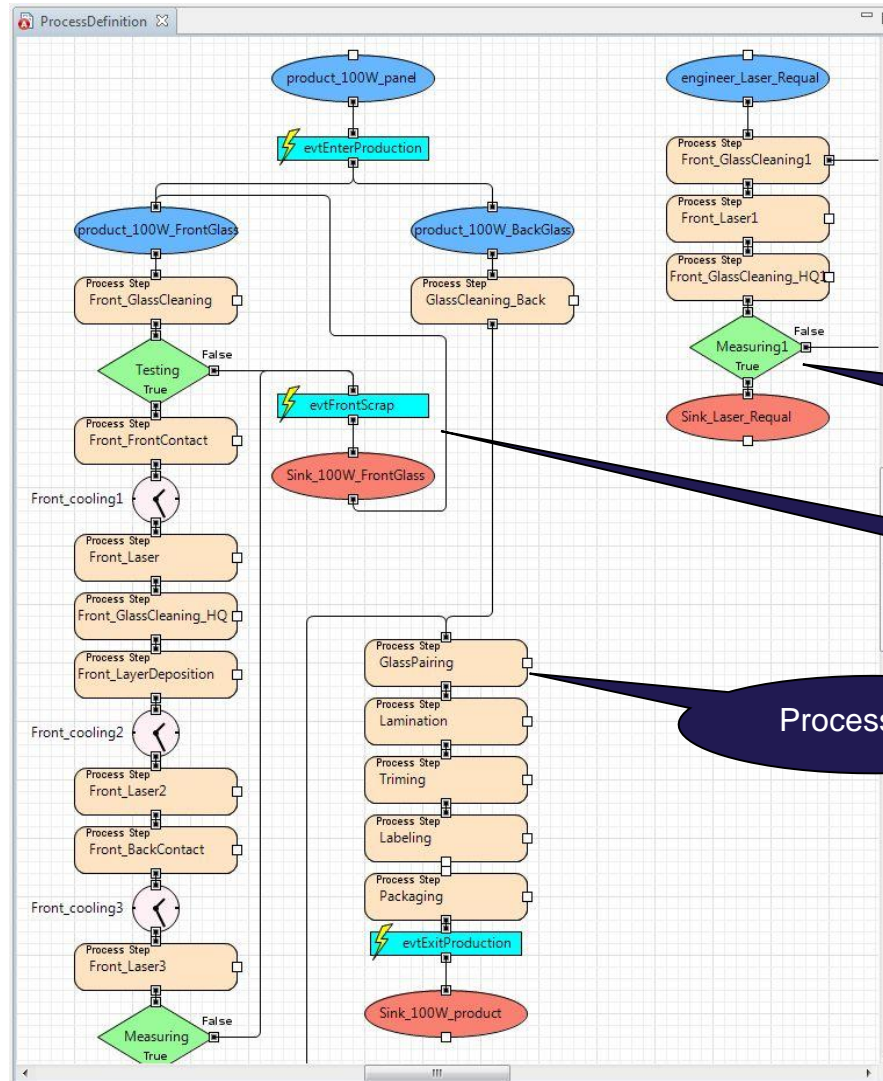

Process Decision Point

Event Sender

Process Step

Simulation Clock – Relative and Absolute Time with the Consideration of Shift and Work Calendars

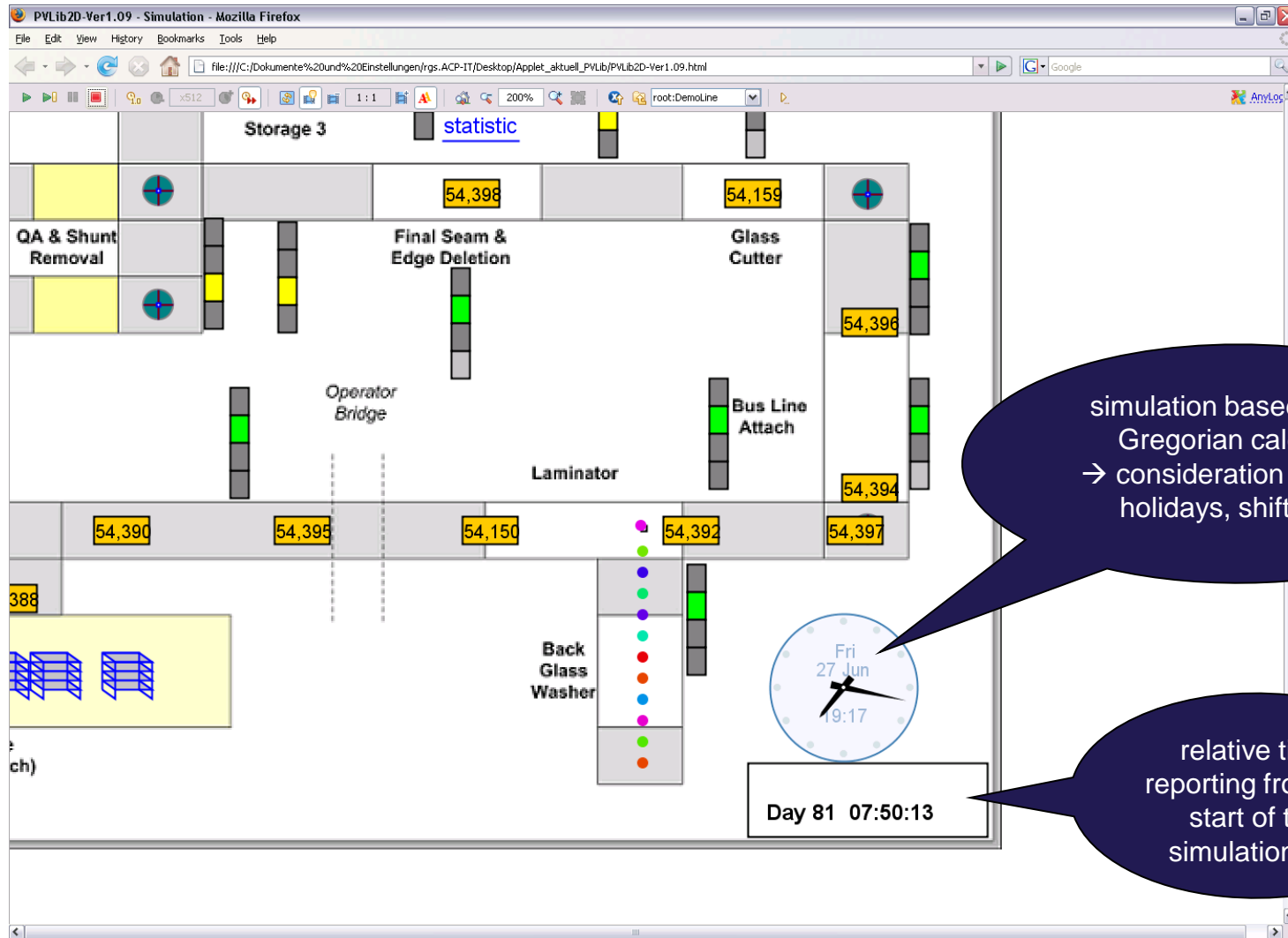

simulation based on the Gregorian calendar
 → consideration of public holidays, shifts etc.

relative time reporting from the start of the simulation run

Online Charts for the Monitoring of Line Performance Metrics

WIP Timeline

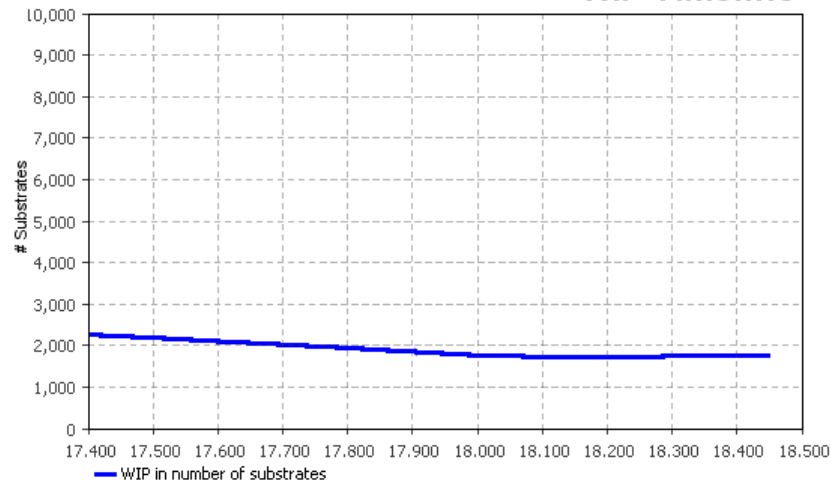

Buffer WIP Timeline

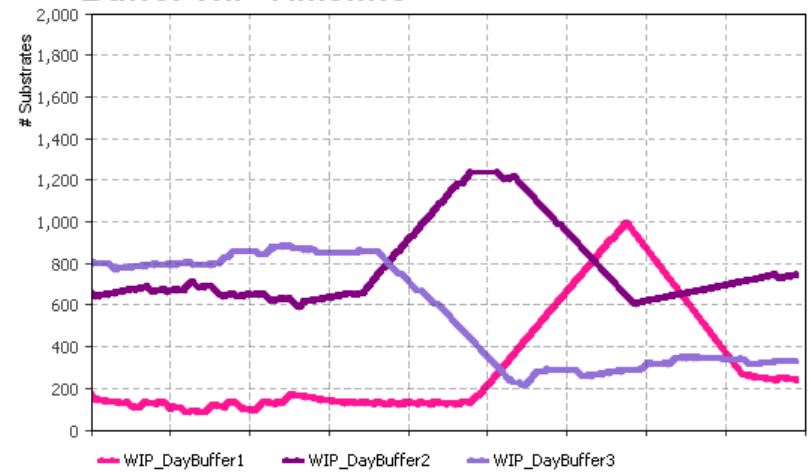

Throughput Timeline

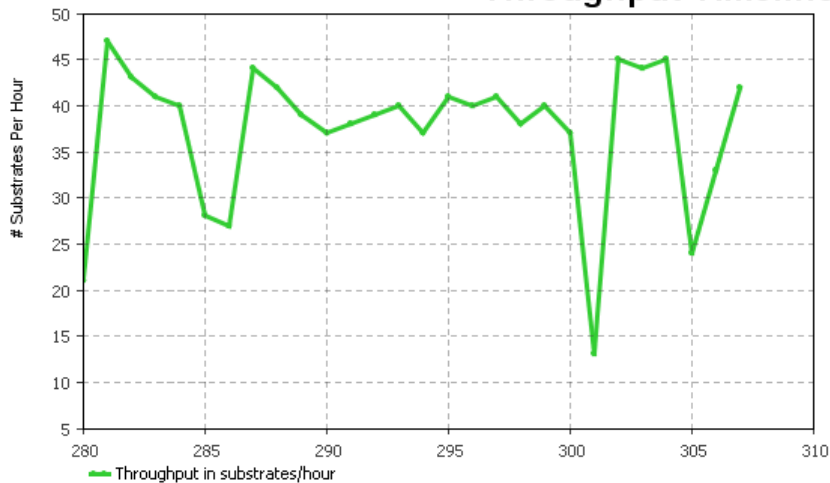

Cycle Time Histogram

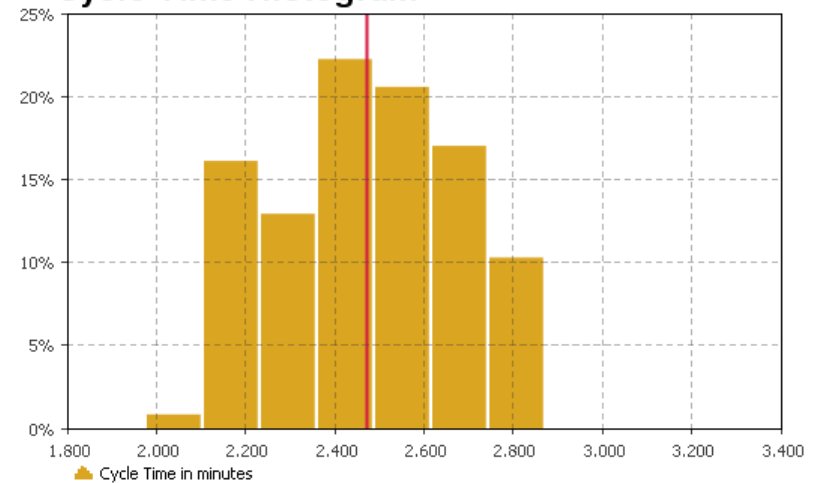

Drag & Drop Configuration of Statistics and Reports

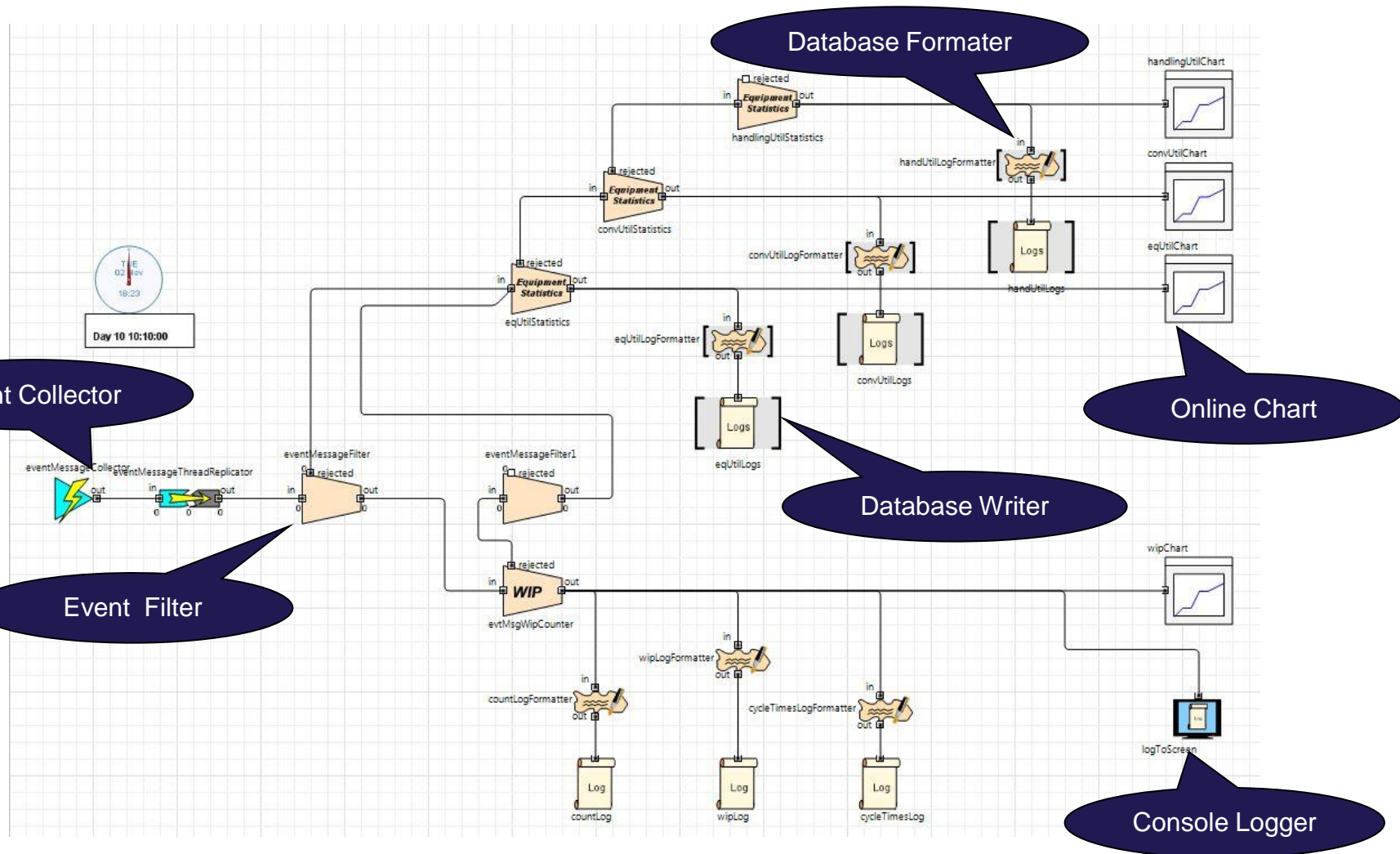

Specific Resource State Models

here: State and Event Model for a Laser Scribe Equipment

Down Event
Laser Scribe 3
Equipment 1

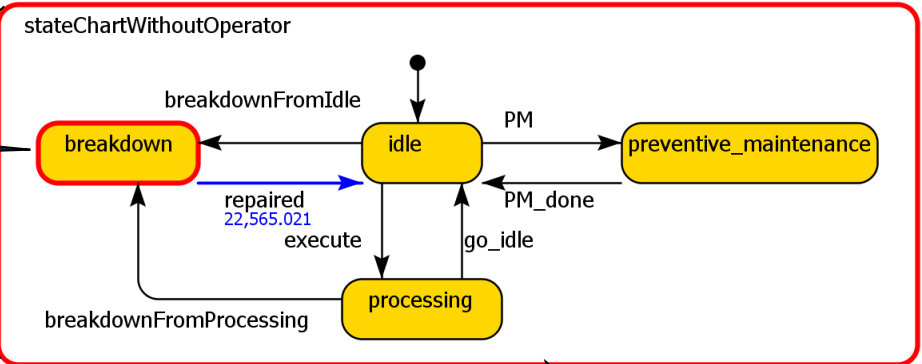

Graphical modelling and configuration of states and events

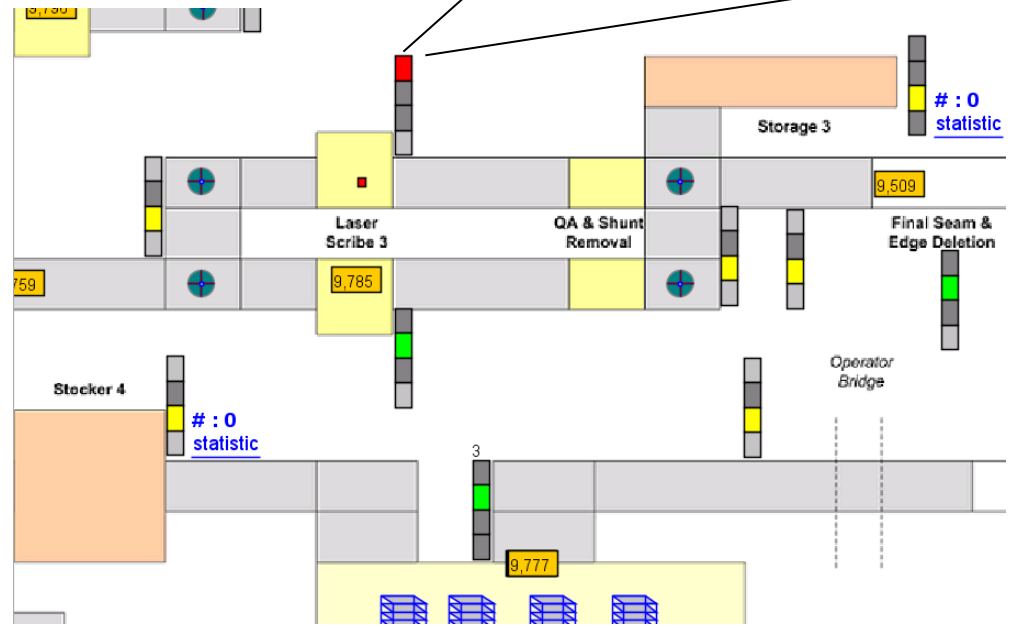

specification of MTBF and MTTR with manifold probability distributions (LogNormal, Weibull, et cetera) as equipment parameters

Detailed Modelling of Timing Behaviour

Unscheduled Down Specification for Equipment and Chamber Level

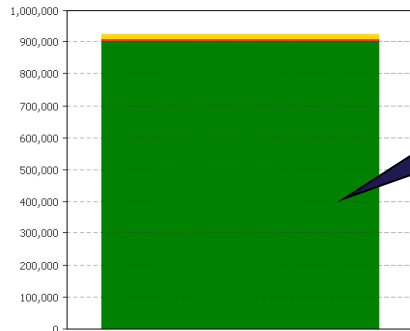

utilisation of equipment

■ processing: 903,752.412 (97.7%)
 ■ breakdown: 4,842.588 (0.5%)
 ■ idle: 16,755 (1.8%)
 ■ preventive_maintenance: 0 (0.0%)

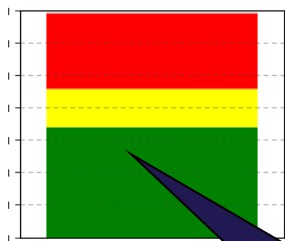

utilisation per chamber

■ processing: 680,586.931 (49.1%)
 ■ idle: 236,201.812 (17.0%)
 ■ breakdown: 464,735.753 (33.5%)
 ■ wait: 5,726.855 (0.4%)

down event for process chamber

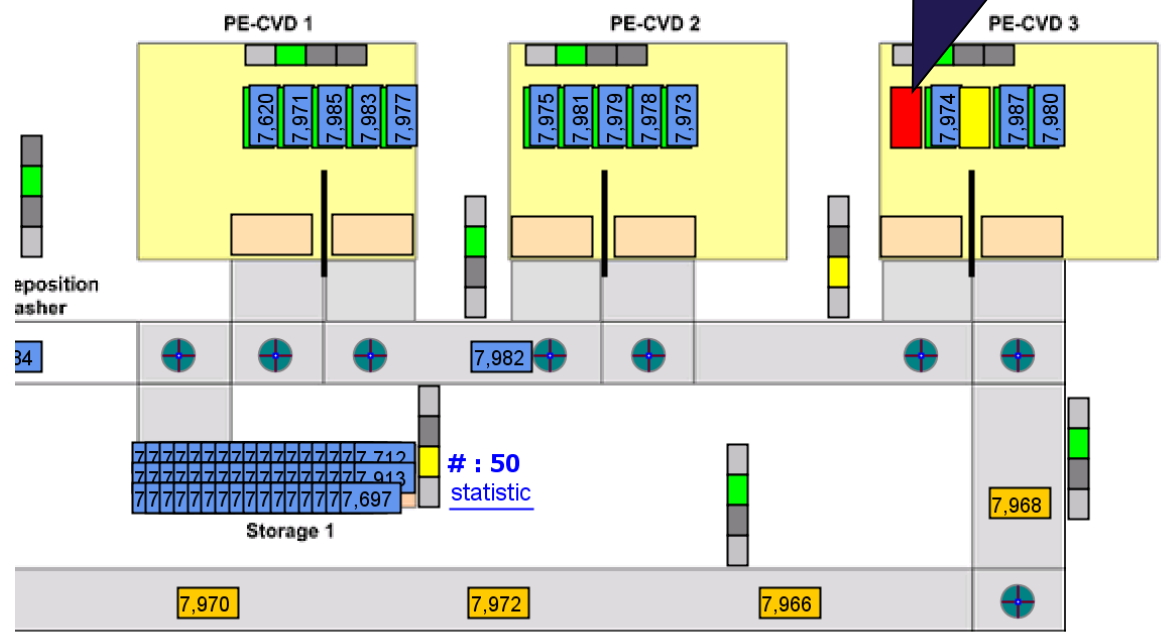

Complex Material Handling Systems

here: Simulation of Central Handler with multiple Stacker Cranes

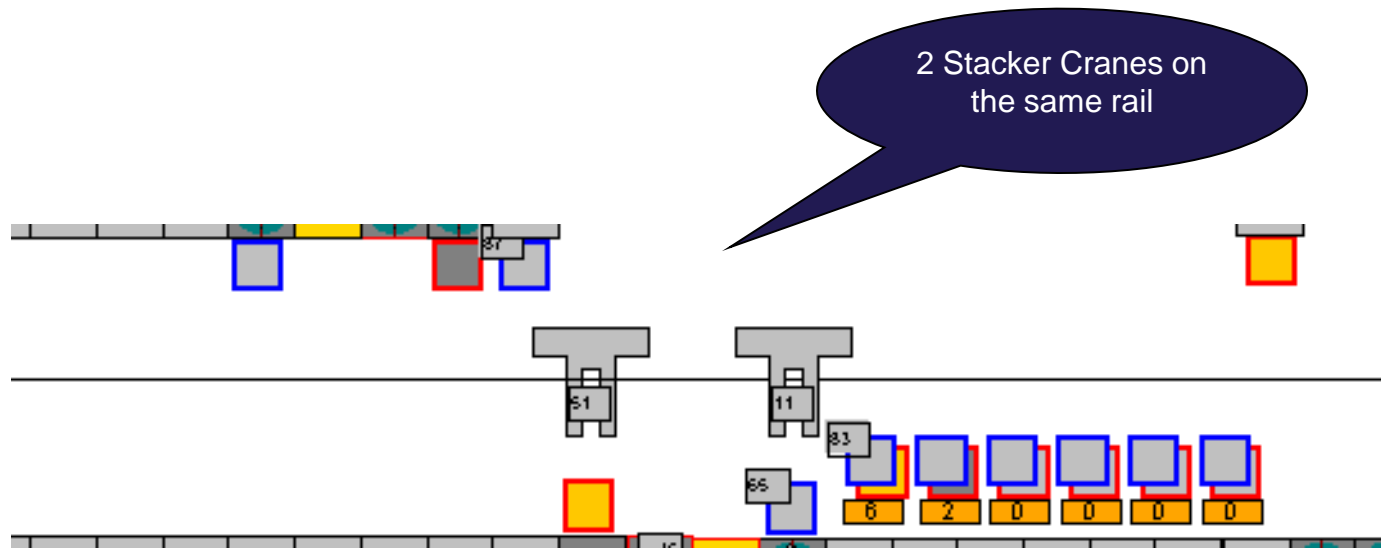

Equipment Parameters Imported Directly from Databases

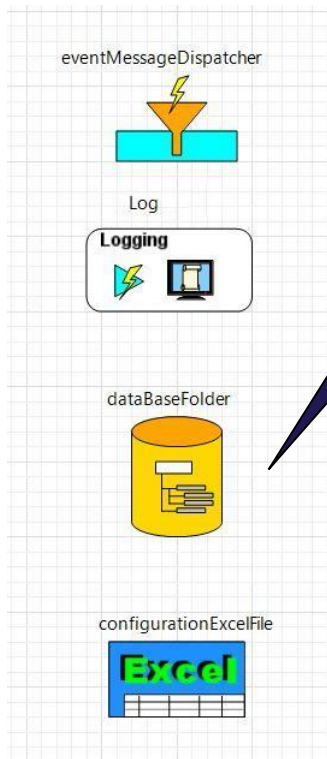

Configuration of Database and Excel Connectivity

Runtime View of Database Configuration

Parameters imported directly from Database

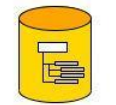

readData

Print

Navigate

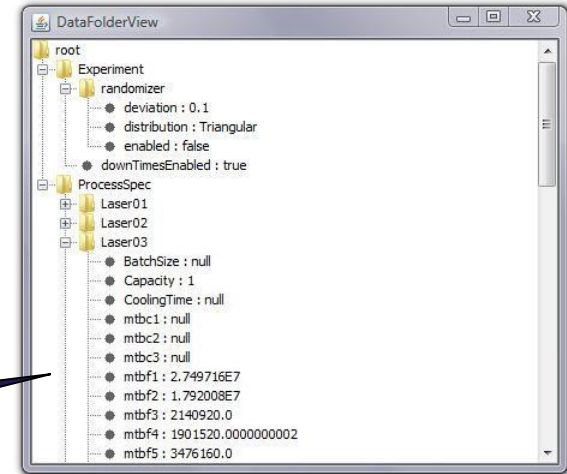

- ProcessingTime
- P** processingTime
- Capacity
- P** capacity

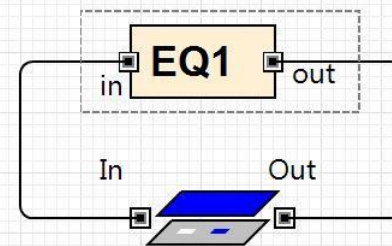

pvMovingSubstrate

Using Simulation Results for a TCO Analysis

- Variability in Material Supply & Safety Levels
- WIP Timeline, Inventory Statistics
- Buffer Capacity
- Required Equipment Capacity
- Product Cycle Time Statistics
- Line Throughput as Timeline
- Overall Line Yield
- Equipment & Line Utilization

TCO: Total Cost of Ownership
FC: Fixed Cost
RC: Running Cost
YC: Yield Cost
L: Lifetime
T: Throughput
Y: Yield
U: Utilization

$$TCO = \frac{FC + RC + YC}{L * T * Y * U}$$

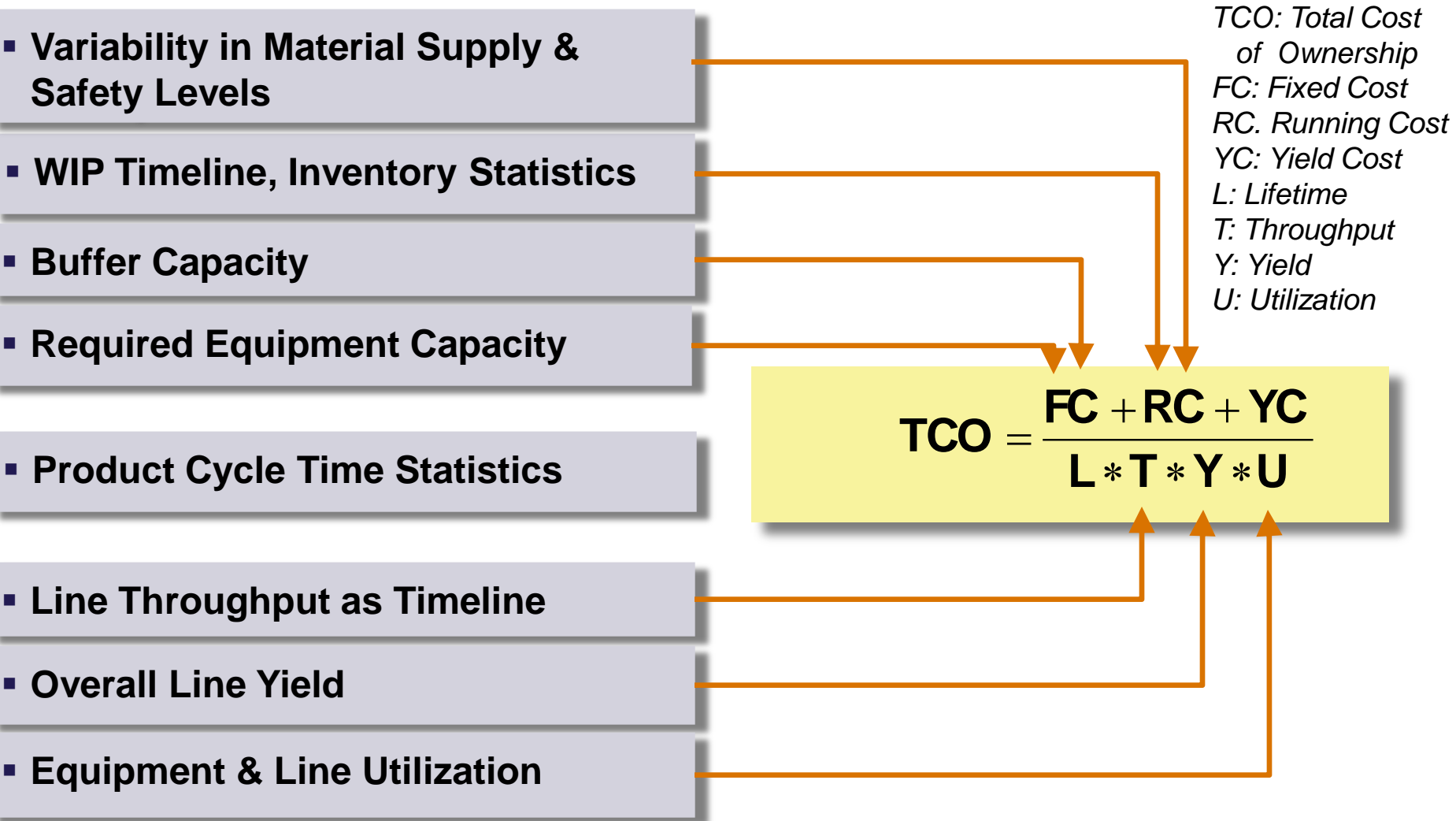

Enabling Factors for a Successful Simulation Project

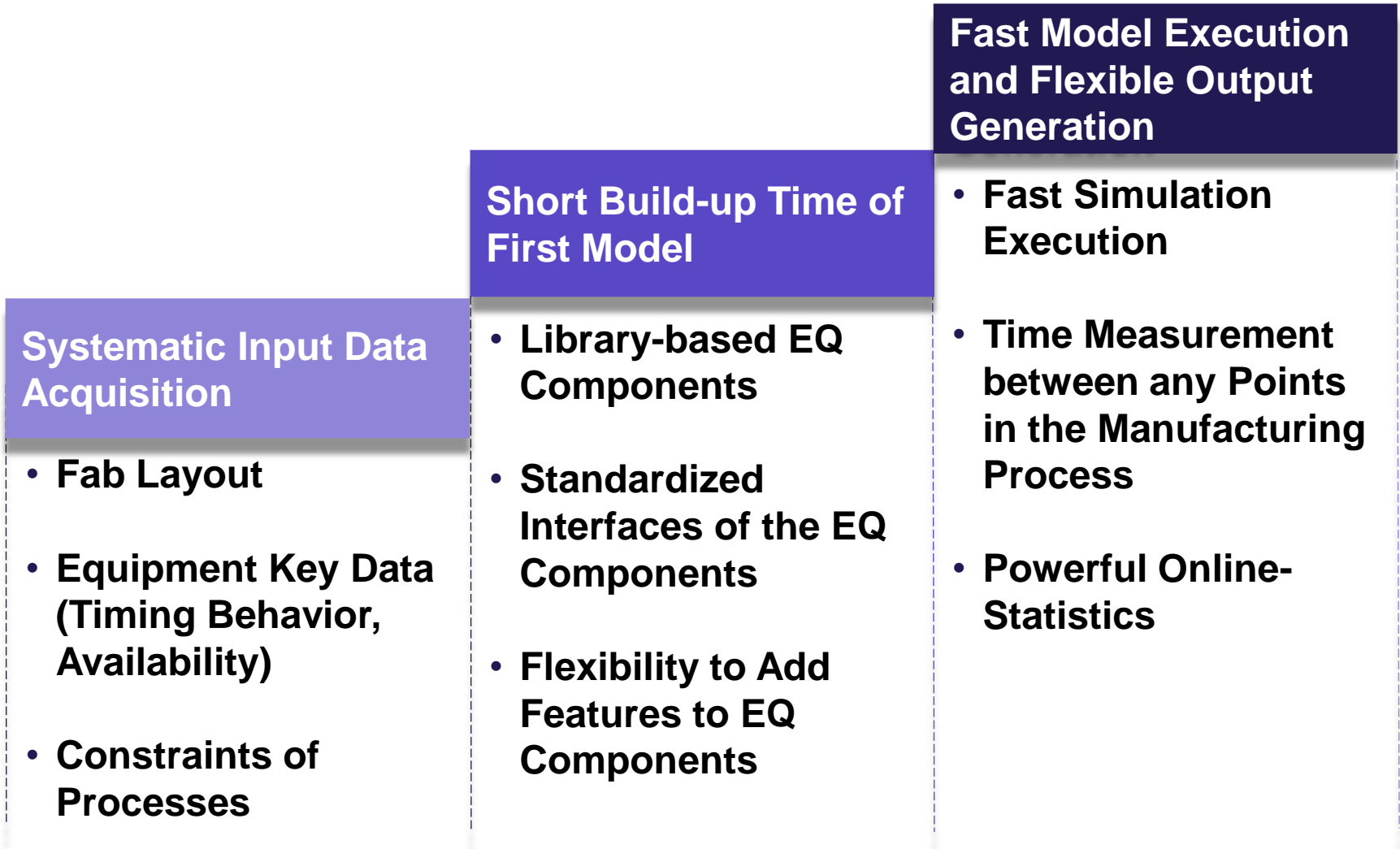

Successful Project Work Enabled by a Common Repository and a Systematic Requirements Tracking for Simulation Project Team

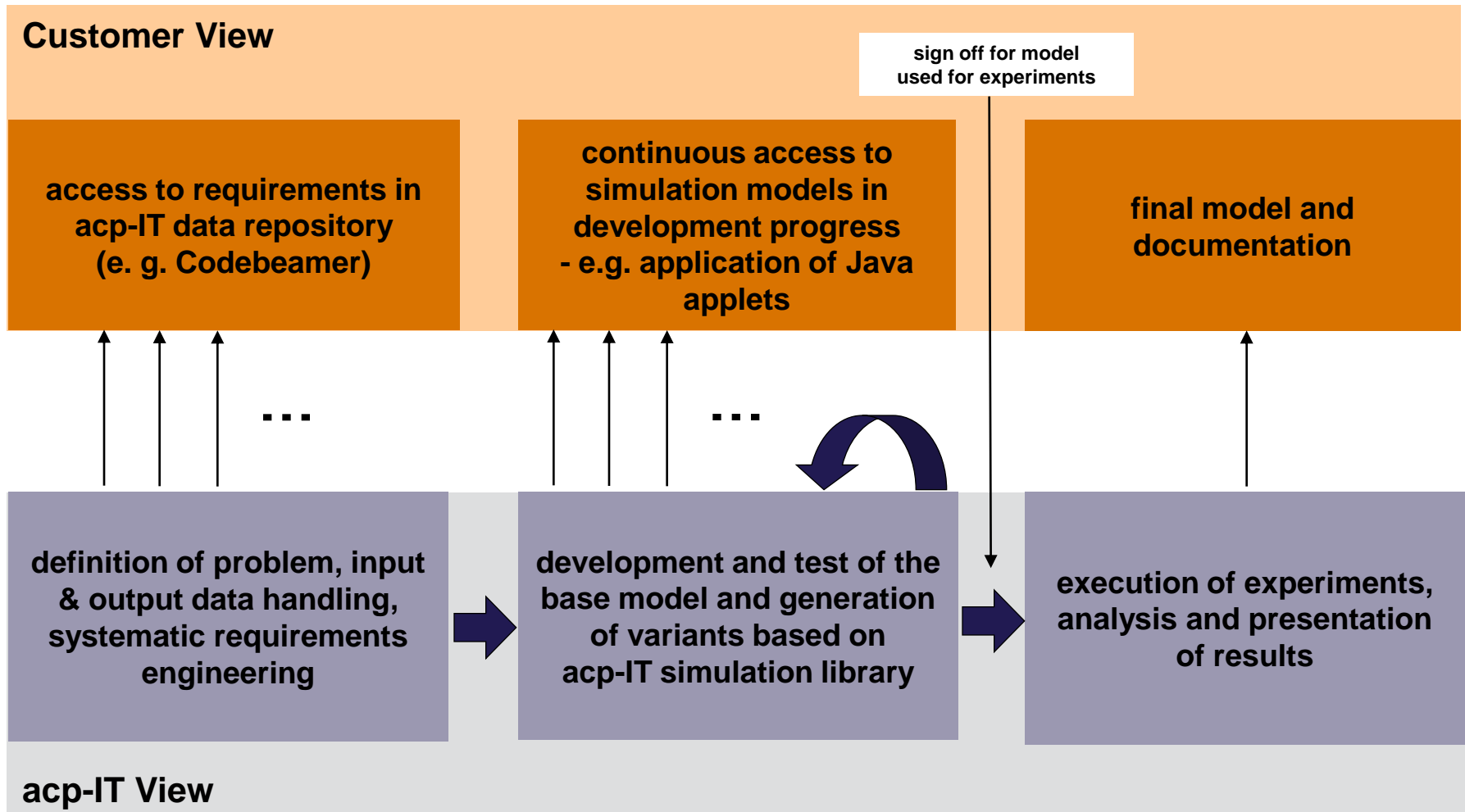

Why AnyLogic?

Advantages Compared with other Simulation Software Packages

- **Object-oriented modelling approach** – allows for a detailed modelling of manufacturing scenarios, the exact timing and state behaviour of processing and material handling equipment aligned with the equipment and line control software
- **Well proven simulation library** from acp-IT which is tailored to the needs of modelling a solar manufacturing line and therefore small effort for the generation of models based on this library
- Short time for the execution of simulation experiments – **outstanding run time performance**
- **Simulation runs in Java Applets** – Model sharing for users without simulation package license and without comprehensive simulation expertise
- **Complete decoupling of animation and control logic** in the simulator
- **Linking of control software** based on **free configurable control events** and therefore easy application of simulation models as emulators for factory control applications
- **Online charts and reports (data sets)** for the monitoring of performance metrics during simulation runs without significant impact to the run time performance
- **Small license costs** – also for industrial and commercial application of the simulation package
- Interface for CAD layout data import



For further information, please contact:

Laurentiu Maniu
eMail: [Laurentiu.Maniu @acp-it.com](mailto:Laurentiu.Maniu@acp-it.com)
Telefon: +49 (0)711-7824089-10

Thank you for your attention.

acp-IT AG

advanced clean production Information Technology AG
Handwerkstr. 29, D-70565 Stuttgart

Telefon +49 (0)711-7824089-0
Telefax +49 (0)711-7824089-10
eMail info@acp-it.de